

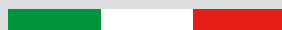

BOSS

MADE IN ITALY





REAL

PREHEAT



Da 60 anni Real Forni lavora nello sviluppo di forni ed attrezzature per l'arte bianca seguendo i professionisti di tutto il mondo in questo importante settore alimentare, la loro soddisfazione è il nostro obiettivo e la nostra migliore pubblicità. Innovazione, ricerca, esperienza e grande rispetto per la tradizione, da qui nasce il nuovo forno rotativo Boss.

For over 60 years Real Forni has been designing and manufacturing bread and pastry ovens with the aim to satisfy the professionals of this important food sector. Their satisfaction is our goal and the best way to promote ourselves. The new rotary oven Boss combines innovation and technology with the yearly experience and tradi-

Seit 60 Jahren arbeitet Real Forni in der Entwicklung von Öfen und Anlagen für das Bäckerhandwerk-Profis aus der ganzen Welt in diesem wichtigen Sektor der Lebensmittel, ist ihre Zufriedenheit ist unser Ziel und unsere beste Werbung. Innovation, Forschung, Erfahrung und großem Respekt für die Tradition, hier kommt die neue Stikkenofen Boss.

Un forno senza compromessi che coniuga caratteristiche uniche rendendolo il riferimento della categoria. Massima efficienza ed ingombri record, cottura perfetta e costi contenuti, Boss è uno strumento che permette di risparmiare energia, spazio e costi di manutenzione con un miglioramento del prodotto.

tion of the company thus becoming the reference model of its category. Maximum efficiency, reduced overall dimensions and low consumptions are the key fetures of BOSS oven that allow the user to save energy and space, reduce the cost of maintenance and improve the result on the baked product.

Ein Ofen ohne Kompromisse, das enthält einzigartige Eigenschaften und ist eine Referenz in der Kategorie. Boss mit seiner maximalen Effizienz und Plattenabmessungen, perfekte Küche und niedrigen Kosten, ist ein Werkzeug, das Ihnen Energie, Raum- und Wartungskosten zu sparen, mit einer Verbesserung des Produktes ermöglicht.



COTTURA PERFETTA

Una buona cottura per un forno rotativo consiste non solo in una corretta distribuzione del calore ma anche nella capacità di sviluppare il prodotto con un flusso d'aria dolce e abbondante, solo così la cottura ventilata può eguagliare quella di un forno statico.

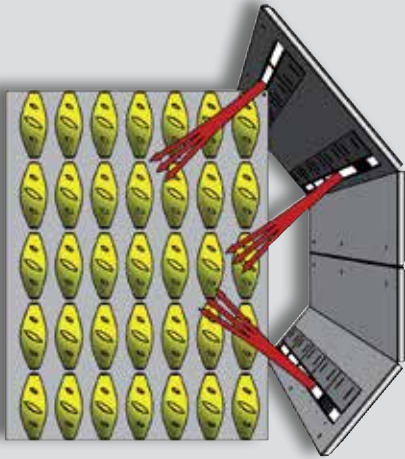

A PERFECT BAKING

A perfect baking in rotary ovens is the result of a correct distribution of the heat and of the ability to bake the product with a gentle and abundant flow of air: this is the only way to equal the baking of a static oven.

EINE PERFEKTE KOCH

Eine gründliche Koch für einen Stikkenofen ist das Ergebnis einer korrekten Verteilung der Wärme und der Fähigkeit, das Produkt mit einem sanften und reichlich Luftstrom backen: das ist der einzige Weg, um die Backen von einem statischen Ofen entsprechen.

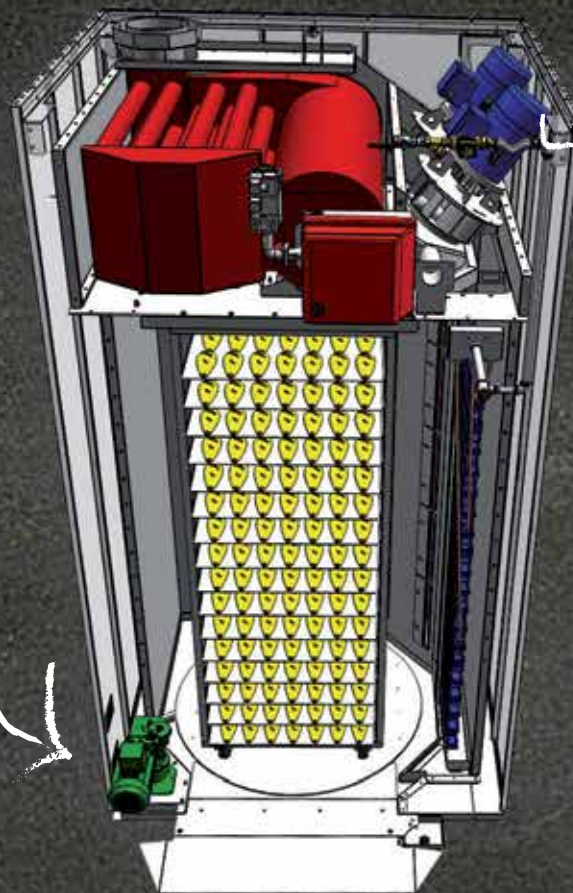

Double
Ventilation

Easy
maintenance



VAPORIERA RAPIDA E POTENTE

Una vaporiera deve vaporizzare una grande quantità di acqua in breve tempo e contemporaneamente avere la capacità di rigenerarsi per la cottura successiva. Grazie ad una vaporiera posta nel mezzo del flusso d'aria il forno Boss garantisce rapidità e potenza, garanzia per ottenere prodotti friabili e con una crosta croccante.

FAST AND POWERFUL STEAMER

A steamer has to produce a big quantity of steam in a short time and generate it for the following baking process. Thanks to its rapid and powerful steamer situated in the middle of the air flow, it is possible to get crisp crust and friable products.

SCHWADENERZEUGER SCHNELLE UND KRAFTVOLLE

Ein Schwadenerzeuger muss eine große Menge Wasser in einer kurzen Zeit zu verdampfen und gleichzeitig die Fähigkeit haben, für die anschließende Brennen regenerieren. Dank einem Schwadenerzeuger in der Mitte des Luftstroms platziert, das Backofen Boss sorgt für Schnelligkeit und Kraft, Sicherheiten brüchig Produkte zu erhalten und mit einer knusprigen Kruste.

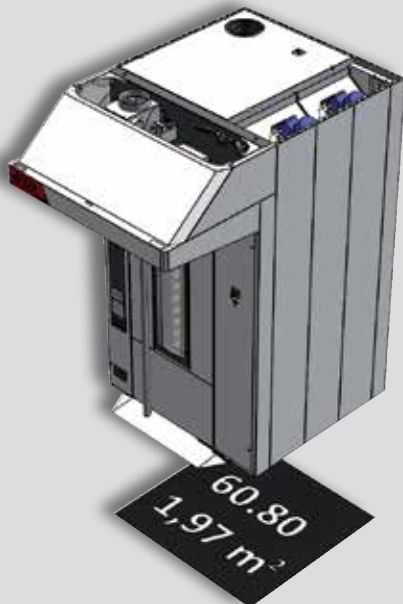

PRIMATO DI EFFICIENZA

Quando un sistema di cottura dotato di due potenti ventilatori e di uno scambiatore di calore a triplo giro di fumi è racchiuso in una coibentazione a tre strati di lana di roccia pressata, i risultati sono tangibili, con una rapida salita in temperatura il forno Boss 60.80 necessita di sole 50.000 kcal/h. Oggi lo spazio all'interno di un laboratorio è una risorsa importante, apprezzerete un forno che vi lascia lo spazio per le vostre future idee.

UNBEATABLE PRODUCTION EFFICIENCY

When a baking system is equipped with two powerful fans and a triple smoke passage heat exchanger and is closed inside a three-layer rock wool cohibentation, results are guaranteed. With a rapid temperature reaching, BOSS 60.80 requires only 50.000 kcal/h. Today the space inside a bakery lab is very precious, you will surely appreciate and oven that leaves some free space for your future projects.

PRIMAT DER EFFIZIENZ

Wenn ein Kochsystem mit zwei leistungsstarken Lüftern und einer Dreifach-Wärmetauscher Runde der Dämpfe ausgestattet ist, in einem Dreischicht-Isolierung aus Steinwolle umschlossen drückte, die Ergebnisse sind greifbar, mit einem raschen Anstieg der Temperatur erfordert das Ofen Boss 60.80 nur 50.000 kcal/h.

Der Raum in einem Labor ist heute eine wichtige Ressource, werden Sie einen Ofen schätzen, die Sie Raum für Ihre Ideen für die Zukunft lässt.

MANUTENZIONE FRONTALE

Tutti gli organi che necessitano di manutenzione si trovano nella parte anteriore e sono facilmente raggiungibili, potrete affiancare più forni ed appoggiarli al muro senza dover perdere spazi utili.

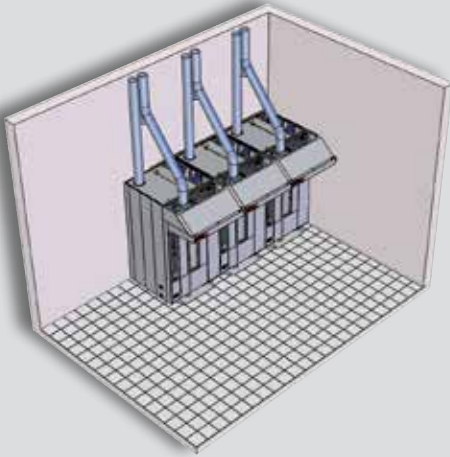

FRONT SIDE MAINTENANCE

All components requiring maintenance are placed in the front side of the oven and are easy to reach. This way it's possible to place ovens side by side and with back side against the wall, thus avoiding space waste.

WARTUNG VORDER

Alle Organe, die Wartung erfordern, werden in der Front befindet und leicht zugänglich sind, können Sie mehrere Öfen kombinieren und unterstützen sie an die Wand, ohne unnötige Leerzeichen zu verschwenden.

PANNELLO TOUCH SCREEN PREDISPOSTO PER INDUSTRIA 4.0



PERFETTA INTEGRAZIONE

Ogni prodotto Real Forni nasce per essere un componente di una squadra vincente, e quindi compatibile con il resto della gamma in ergonomia, dimensioni e design. Questa caratteristica crea un'armonia all'interno del laboratorio prerogativa di un ambiente di qualità. (VapoTech AT5c + Boss 60.80)

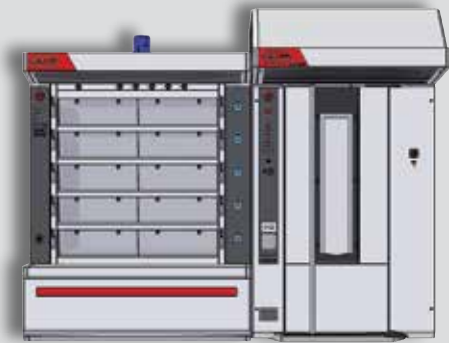

PERFECT INTEGRATION

Each Real Forni product is designed to be a component of a winning team, and therefore compatible with the rest of the company's range in ergonomics, size and design. This feature creates aesthetic harmony within the laboratory, this is a prerogative of quality workplaces.

PERFEKTE INTEGRATION

Jedes Produkt Real Forni ist entworfen, um eine Komponente eines erfolgreichen Teams zu sein, und daher vereinbar mit dem Rest der Serie in der Ergonomie, Größe und Design. Diese Funktion schafft eine Harmonie innerhalb des Labors und das ist ein Vorrecht der Qualität Umgebungen. (VapoTech AT5c + Boss 60.80)

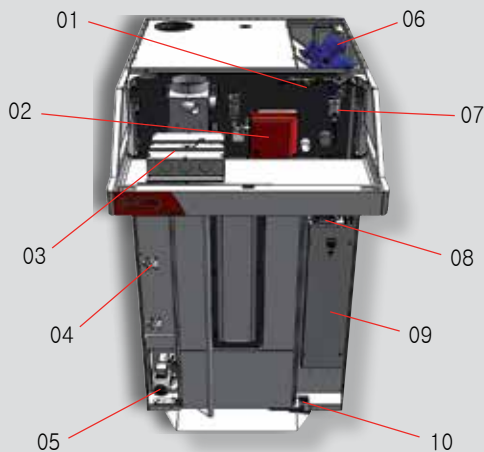

Tutto a portata di mano!
Everything close at hand!
Alles zur Hand!

- 01 Elettrovalvola ingresso acqua
- 02 Bruciatore / collegamenti resistenze
- 03 Aspiratore vapori
- 04 Illuminazione
- 05 Motoriduttore rotazione
- 06 Ventilatori
- 07 Elettrovalvola scarico vapori
- 08 Ingresso acqua nel forno
- 09 Cassetta di potenza
- 10 Fermo porta aperta

- 01 Electrovalve for water inlet
- 02 Burner / heating elements
- 03 Steam extraction fan
- 04 Lights
- 05 Gear-motor for platform rotation
- 06 Fans
- 07 Steam exhaust electrovalve
- 08 Water inlet in the oven
- 09 Power box
- 10 Door limit switch

- 01 Magnetwasserzulauf
- 02 Brenner / Elektrische Widerstände
- 03 Abgase
- 04 Beleuchtung
- 05 Getriebemotor Rotation
- 06 Ventilatoren
- 07 Magnet Abgase
- 08 Wassereintritt in den Ofen
- 09 Kaution Macht
- 10 Noch offen Tür



BOSS PANORAMA 60.100





PANORAMA è la versione ideale per laboratori o centri commerciali e permette ai clienti di avere una visuale privilegiata sulla cottura in corso mantenendo nel contempo il laboratorio lontano da occhi indiscreti. Disponibile anche con schermo LCD posteriore per la visualizzazione del prodotto e dello stato del processo di cottura.

PANORAMA is the BOSS version perfect for laboratories or shopping malls that allows customers to have a direct view on the baking process of the products and at the same time to keep the working area safe from prying eyes. It's available also with LCD screen on the back of the oven to check the baking process.

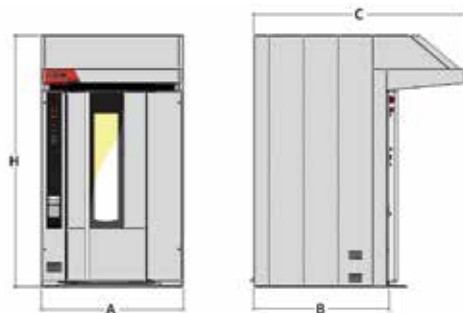

Die Version PANORAMA ist ideal für Laboratorien oder Einkaufszentren. Sie ermöglicht Kunden einen direkten Blick auf den Produkten und zur gleichen Zeit um das Labor sicher vor neugierigen Augen zu halten. Sie ist verfügbar auch mit Rück LCD-Bildschirm für die Anzeige der Produkt- und der Zustand des Kochvorgangs.





Boss**Boss 50.70 - Boss 50.70 E**

cm 	n.	cm 	m ²	A mm	B mm	C mm	H mm	50.70 Kcal/h	50.70 E kW
50x70	16/18	9/8	5,6/6,3	1310	1240	2040	2260	30.000	28,0
40x80	16/18	9/8	5,1/5,8						
40x60	16/18	9/8	3,8/4,3						
45x65	16/18	9/8	4,7/5,3						
18"x26"	16/18	9/8	4,8/5,4						



Boss 60.80 R - Boss 60.80 R E

cm 	n.	cm 	m ²	A mm	B mm	C mm	H mm	60.80 R Kcal/h	60.80 R E kW
60x80	16/18	9/8	7,7/8,6	1440	1370	2150	2340	45.000	36,0
20"x30"	16/18	9/8	6,2/7,0						



Boss 60.80 - Boss 60.80 E

cm 	n.	cm 	m ²	A mm	B mm	C mm	H mm	60.80 Kcal/h	60.80 E kW
60x80	18/20	9/8	8,6/9,6	1440	1370	2150	2540	50.000	43,0
20"x30"	18/20	9/8	7,0/7,7						

Boss 60.100 - Boss 60.100 E

cm 	n.	cm 	m ²	A mm	B mm	C mm	H mm	60.100 E Kcal/h	60.100 E kW
60x100	18/20	9/8	10,8/12,0	1600	1530	2310	2540	62.000	49,8
n.218"x26"	18/20	9/8	10,9/12,1						
60x90	18/20	9/8	9,7/10,8						
80x80	18/20	9/8	11,5/12,8						

Boss 80.100 - Boss 80.100 E

cm 	n.	cm 	m ²	A mm	B mm	C mm	H mm	80.100 Kcal/h	80.100 E kW
80x100	18/20	9/8	14,4/16,0	1725	1655	2440	2590	80.000	56,5
80x90	18/20	9/8	13,0/14,4						
n.220"x30"	18/20	9/8	13,9/15,5						

Immagini e dati tecnici sono indicativi, la ditta si riserva la facoltà di apportare modifiche senza comunicarlo.



Panorama

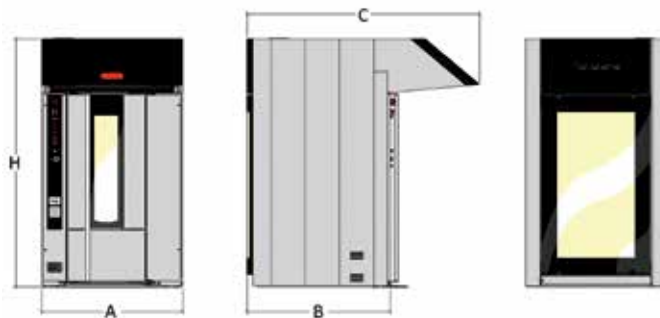

Panorama 60.80 - Panorama 60.80 E

◇ cm	n.	cm □	m ²	A mm	B mm	C mm	H mm	60.80 Kcal/h	60.80 E kW
60x80	18/20	9/8	8,6/9,6	1440	1480	2390	2540	50.000	43,0
20"x30"	18/20	9/8	7,0/7,7						

Panorama 60.100 - Panorama 60.100 E

◇ cm	n.	cm □	m ²	A mm	B mm	C mm	H mm	60.100 E Kcal/h	60.100 E kW
60x100	18/20	9/8	10,8/12,0	1600	1650	2530	2540	62.000	49,8
n.218"x26"	18/20	9/8	10,9/12,1						
60x90	18/20	9/8	9,7/10,8						
80x80	18/20	9/8	11,5/12,8						

Immagine e dati tecnici sono indicativi, la ditta si riserva la facoltà di apportare modifiche senza comunicarlo.



CARATTERISTICHE / CHARACTERISTICS / MERKMALE

- Massima efficienza • Minimo ingombro • Cottura impeccabile
- Vaporizzazione abbondante • Semplice manutenzione • Design curato
- Maximum production efficiency • Minimum overall dimensions • Perfect baking
- Abundant vaporization • Easy maintenance • Accurate design
- Maximale Effizienz • Minimaler Platzbedarf • Perfectes Backergebnis
- Verdampfung tadellosen reichlich • Einfache Wartung • Gepflegt Design

ACCESSORI DI SERIE / AS STANDARD / SERIENAUSSTATTUNG

- Piattaforma inferiore per rotazione carrello • Valvola scarico vapori motorizzata
- Pannelli laterali in acciaio inox • Aspiratore in polipropilene con cassa in acciaio inox
 - Allarme di fine cottura con lampeggiatore
- Lower platform for trolley rotation • Motorized steam extraction valve
- Stainless steel side panels • Polypropylene extractor fan with stainless steel volute
 - End of baking alarm with flashing light
- Niedrigere Plattform für Wendung des Warenkorb • Motorisierte Steam-Ablauf-Ventil
- Seitenwänden aus Edelstahl • Edelstahl Saug Polypropylen mit Edelstahlgehäuse
 - Alarm Ende der Garzeit mit Blink

ACCESSORI OPZIONALI / AS OPTIONAL / OPTIONALES ZUBEHÖR

- Dispositivo per utilizzare carrelli con aggancio superiore
 - Uscita fumi dalla parete posteriore del forno
 - Centralina con programmatore LCD Touch
- Upper hooking device for trolleys
- Smoke outlet in the back of the oven
- Junction box with LCD Touch programmer
- Gerät für die Verwendung mit Stapleranbau oben
 - Rauchabzug von der Rückwand des Ofens
 - Steuereinheit mit LCD Touch –Programmierer



50.70

60.80 R

60.80

60.100

80.100



Via Casalveghe, 34 – 37040 Gazzolo D'Arcole – Verona (Italy)
 Tel. +39 045 6182033 +39 045 6182015 – Fax. +39 045 6182019
 www.realforni.com – realforni@realforni.com